

IRAQI

Academic Scientific Journals

Alkadhim Journal for Computer Science
(KJCS)Journal Homepage: <https://alkadhim-col.edu.iq/JKCEAS>

Improving Communication Performance Through Fiber Amplifier EDFA

¹Baedaa S. Zynal, ²Alaa Thaer Lateef, ³Sabah Abdulazeez Jebur and ⁴Hayder A. Naser*

^{1,3,4} Department of Computer Techniques Engineering, Imam Alkadhim University College (IKC), Baghdad, Iraq

² Materials Research Directorate, Ministry of Science and Technology, Baghdad, Iraq

Article information

Article history:

Received: May, 20, 2024

Accepted: Jun, 11, 2024

Available online: Jun, 14, 2024

Keywords:

EDFA,

Communication systems,

Erbium-doped fiber amplifiers

*Corresponding Author:

Hayder A. Naser

hayder.a.naser@gmail.com

DOI:

<https://doi.org/10.53523/ijoirVolxIxDxx>

This article is licensed under:

[Creative Commons Attribution 4.0](https://creativecommons.org/licenses/by/4.0/)

[International License.](https://creativecommons.org/licenses/by/4.0/)

Abstract

Due to the development of fast and extensive data communication methods, typical erbium-doped fiber amplifiers (EDFA) have recently gained much interest. The main advantage of EDFA is its ability to build a system with a broad band. However, it is evident from documented works that using EDFA results in a gain increase. Nevertheless, the expense, complexity, and subpar effectiveness of these procedures made them ineffective. In this work, the performance of an 8-channel communication system for different distances of 80, 120, and 180 km is enhanced and maximized by applying a simulation model of long distance based on EDFA to reduce the effects of dispersion correction. The effect of the EDFA on three channels was investigated along the three distances by Q Factor and BER. The proposed system achieved good results in enhancing signals due to EDFA. The results of the extraction demonstrate the system's capacity to send large data rates to 180 km with a bit error rate of less than 1×10^{-14} . EDFA shows the best performance in gain differences. The simulation setup and implementation of the work aim to improve communication performance and propose a suitable solution to enhance the Bit Error Rate (BER).

1. Introduction

According to information uprising, networks based on the internet need a lot of bandwidth to allow for the transmission of information between many sites. Modern fiber optic-based systems are the only ones capable of transmitting data at such a wide bandwidth due to their extremely low transmission link signal degradation losses [1-2]. The amplitude deterioration was initially very poor and regularly caused signal degradation without being taken into account in the transmission systems based on industry, with a reduction of up to 1000 dB/km [3]. Later, in 1970, scientists made a significant advancement in this approach when they developed an optical fiber with a 20 dB/km attenuation. This increased the reliability of fiber optics for the transmission of light and data. The amplitude decreasing level also dropped to 0.2 dB/km and became generally available as efforts to enhance fiber optic potential advanced. As the link length increases, the signal power of the pulses in the fiber-optic communication system decreases. The attenuation or losses caused by the length of the fiber optic cable can be decreased [4-6]. Nevertheless, for systems that employ multicarrier multiplexing or wavelength division multiplexing (WDM), the aforementioned procedure may become comparatively costly and difficult. The optical in-line amplification solution involves incorporating optical amplifiers into optical fiber networks to

simultaneously amplify the whole channels in the optical signals multiplexing system [7]. Photodetectors are required for the purpose of obtaining the digital signals in electrical form, and they are incorporated inside the receiver [8]. In closely spaced dense wavelength division multiplexing (DWDM) networks, signal amplitude loss, pulse width widening, and non-linear impairments worsen [9]. In order to meet the high-capacity requirements of DWDM systems, wide-band EDFAs are much desired and anticipated [10]. EDFA models are simple to develop and provide a quick and accurate estimation of optical system behavior [11]. The modal gain equalization and signal transmission stability of few-mode fiber amplifiers improve with increasing erbium doping concentrations [12]. A long-haul optical communication system would benefit from the EDFA's practical implementation [13]. EDFA models were studied mathematically to determine their efficiency in optical chains to obtain a flat gain for 8 WDM channels when implemented in EDFA models [14]. With the EDFA, a 50 Gb/s 4-level PAM4 system gains 34.78 % more fiber length than without them. Further, the optimal system will have a 6 dB reduction in launch optical power [15]. EDFAs were used with multi-band transmission (MBT) technology by [16]. A prototype of a 15.2 km long submarine cable has been developed using EDFA by [17]. In this study, the data transmission of 1 to 10 Gbps and a single EDFA amplifier were examined using Optisystem software. Communication system performance is enhanced and maximized by applying specific efficient ways for reducing the effects of dispersion correction.

2. Materials and Methods

Eight transmitters would be used in the suggested schemes of this work to transmit the signal through SMF links at varied distances. There would be eight remote stations for the receiver. OptiSystem software version 17.1 would be used to simulate the suggested systems. Fig. 1 illustrates the overall perspective of the eight-channel system that is proposed. The three primary components of the suggested system are shown in the list below.

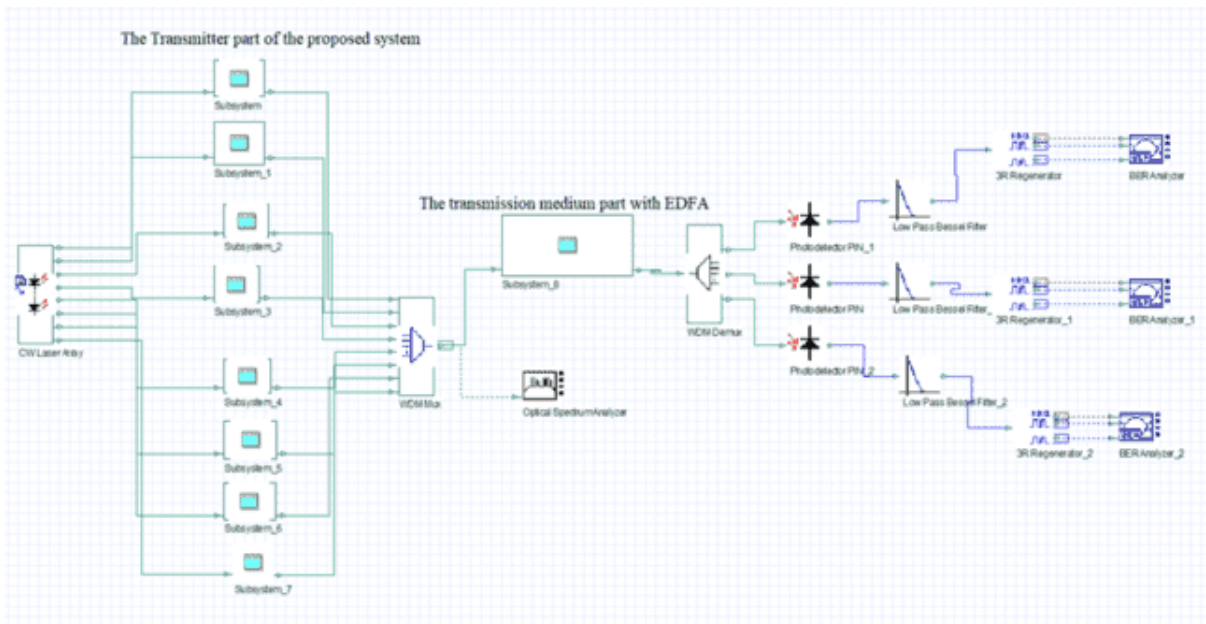

Figure (1): The proposed system for 8 channels

2.1 Transmitter Part

Each transmitter is equipped with a pulse generator, a CW, a PRBS, a dedicated channel, and a wavelength that is appropriate for its operating range. For each transmitter, a PRBS generator generates binary data that is later converted into electrical pulses by an NRZ pulse generator for use wideband pulse. Following that, the transmitter would be the Laser power. The electrical signal and optical laser signal for each channel would then be combined

using the MZM, as shown in Fig. 2. The frequency used for each channel began at 191.5 THz, with a 0.2 GHz frequency spacing, a linewidth of 0.1 MHz, and a strength of 0 dBm for CW laser. Additionally, 40 Gbps is the chosen bit rate for each channel. Each link would connect each input channel in the proposed scheme's multiplexer, which had a bandwidth selection of a 50 GHz signal combination link.

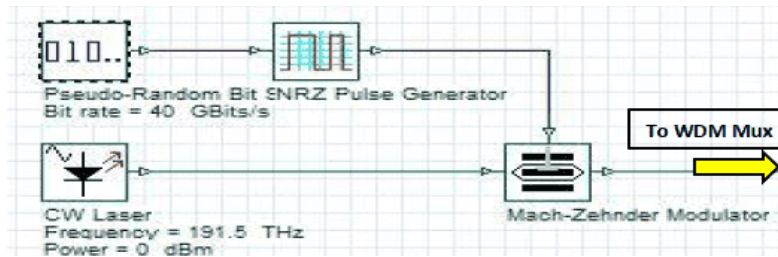

Figure (2): The Transmitter part of the proposed system.

2.2. Transmission Medium Part

Using sequence management, the dynamically frequency modulation are sent over the chosen distances of 60, 120, and 180 km as shown in Fig.3. By adjusting it to 0.2 dBm/Km and 16.75 ps/nm/Km, respectively, the attenuation and dispersion effects will be considered in the system implementation and quality analysis of our provided solutions. Continuous wavelet transform would become an issue due to the lengthier transmission. Therefore, dispersion adjustment is necessary to increase transmission distances. As a result, a dispersion compensating fiber (DCF) was created with this objective in mind. The EDFA is the most often transmitted fiber amplifier in this sector because its intensification window fits the third transmission window of particulate optical fiber.

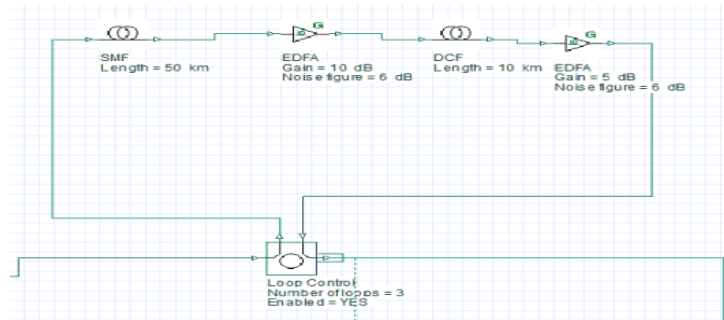

Figure (3): The transmission medium part with EDFA

A laser operating at or near the wavelengths of 980 nm and 1480 nm can be used to successfully remove trivalent erbium particles (Er^{3+}) doped in the middle of a silica fiber. Gain is visible at 1550 nm. Depending on the application, the EDFA enhancement district's size might range between a few and 80 nanometers. Conventional or C-band intensifiers (from 1525 nm to 1565 nm) or long, or L-band speakers (from 1565 nm to 1610 nm), are required when employing EDFA in broadcast communications. EDFAs can assist any of these categories, however it is common to use two presenters who can assist several groups. Table 1 provides a list of the EDFA parameters that were applied.

Table (1): The selected parameters of the utilized EDFA

Parameters of EDFA	Parameter Value
Gain	10dB, 5dB
Noise figure	6dB
Operation mode	Gain control
Power	10dB
Saturation power	10dB
Include noise	Yes

The DCF has also been used to apply a fiber loop with a negative dispersion that corresponds to the dispersion of the communication line. employing pre-compensation techniques to implement mix correction between two optical amplifiers, at the beginning, or at the conclusion (post-compensation methods). Table 2 contains a list of the parameters used in the DCF of our suggested system.

Table (2): The chosen DCF parameters that were used.

Parameters of DCF	Parameter Value
Length	10 km
Attenuation	0.5dB/km
Dispersion	-85ps/nm/km
Dispersion Slope	-0.3ps/nm ² /k
Group Velocity Dispersion	Yes
Third-Order Dispersion	Yes

2.3. Receiver Part

Figure 4 shows the receiver, which consists of a portrait of the PIN type for transforming the optical signal converted into an electrical signal, a Low Pass Bessel Filter (LPBF) with a cutoff frequency of 0.80 bit rate value, a 3R generator, a BER analyzer, a 1× 8 demultiplexer for recombining optical signals, and finally. The fact that LPBF was utilized to split the RF waves from each participant must be remembered. It is also used to control the nonlinear characteristics of resonance, improving the quality of the system. The effectiveness of our suggested method will be evaluated using the BER analyzer, taking into account the Q-factor, Min BER, and eye parameters.

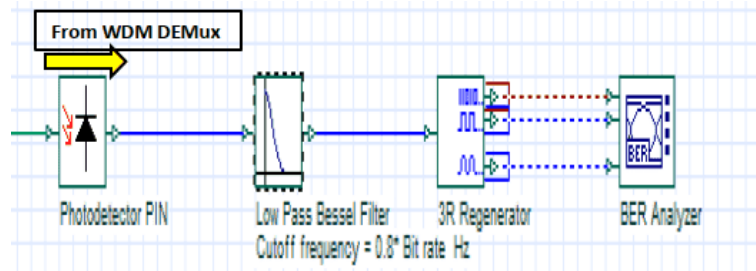

Figure (4): The receiver part of our proposed system.

3. Results and Discussion

A few of the variables that would be employed to control the performance inquiry are the eye diagram, Q-factor, Min BER, and optical spectrum analysis. Additionally, a technique for optimization has been looked into and suggested in this part by raising the CW laser device's input power, as will become clear.

3.1. Optical Spectrum Analyzing

Using a specialized optical analyzer instrument and as shown in Fig. 5, the optical spectrum has been detected after being multiplexed by an 8×1 multiplexer. The first proposed scheme's performance would be evaluated based on a number of factors for three selected channels, 1, 4, and 8.

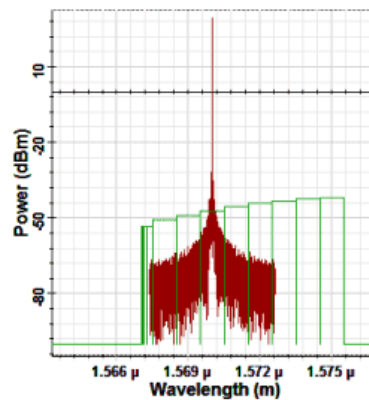
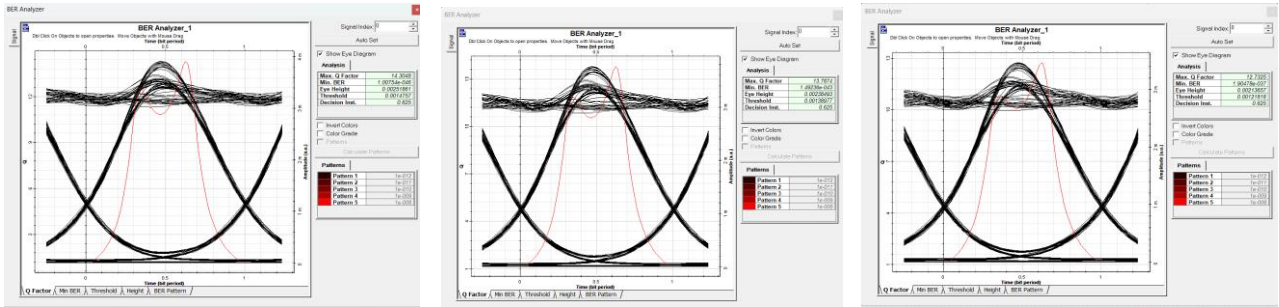

Figure (5): The optical spectrum of one channel

3.2. Eye Diagram parameter

The original parameter was the eye diagram, which could display the quality of the signal received. The eye diagrams for the selected channels at distances of 60, 120, and 180 kilometers is shown in Figure 6 and 7. Both with and without the EDFA presentation. At closer ranges, it may detect a distinct eye, indicating that the signal received for these specific channels was of greater quality. While at greater distances, it was obvious that our system's use of the EDFA had an impact on how well eyes were opened.

(a)



(b)

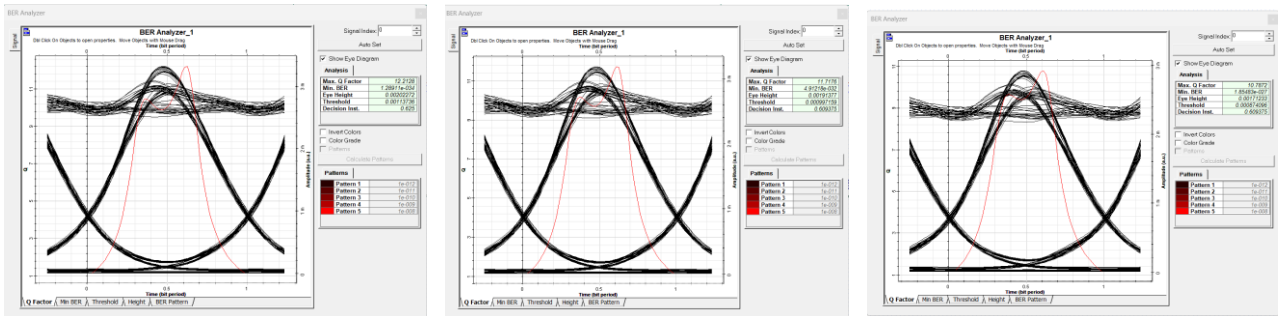

(c)

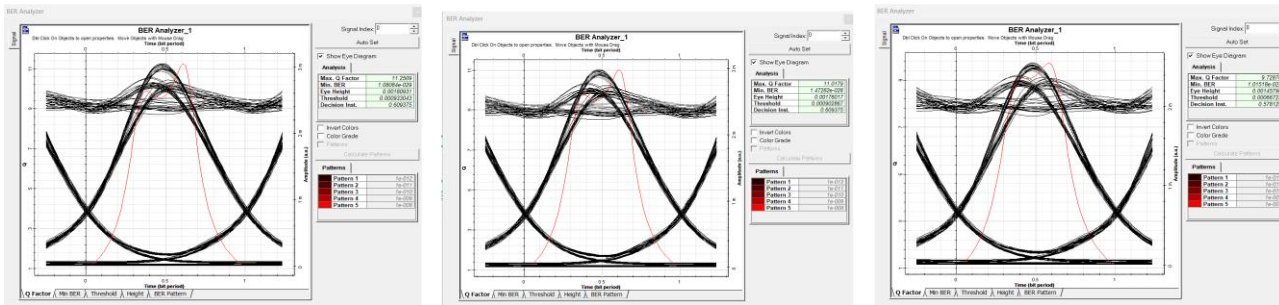

Figure (6): Eye diagram of the 320 Gbps DWDM system without the EDFA presentation at 60 km, 120 km, and 180 km, respectively for (a) channel 1, (b) channel 4, and (c) channel 8.

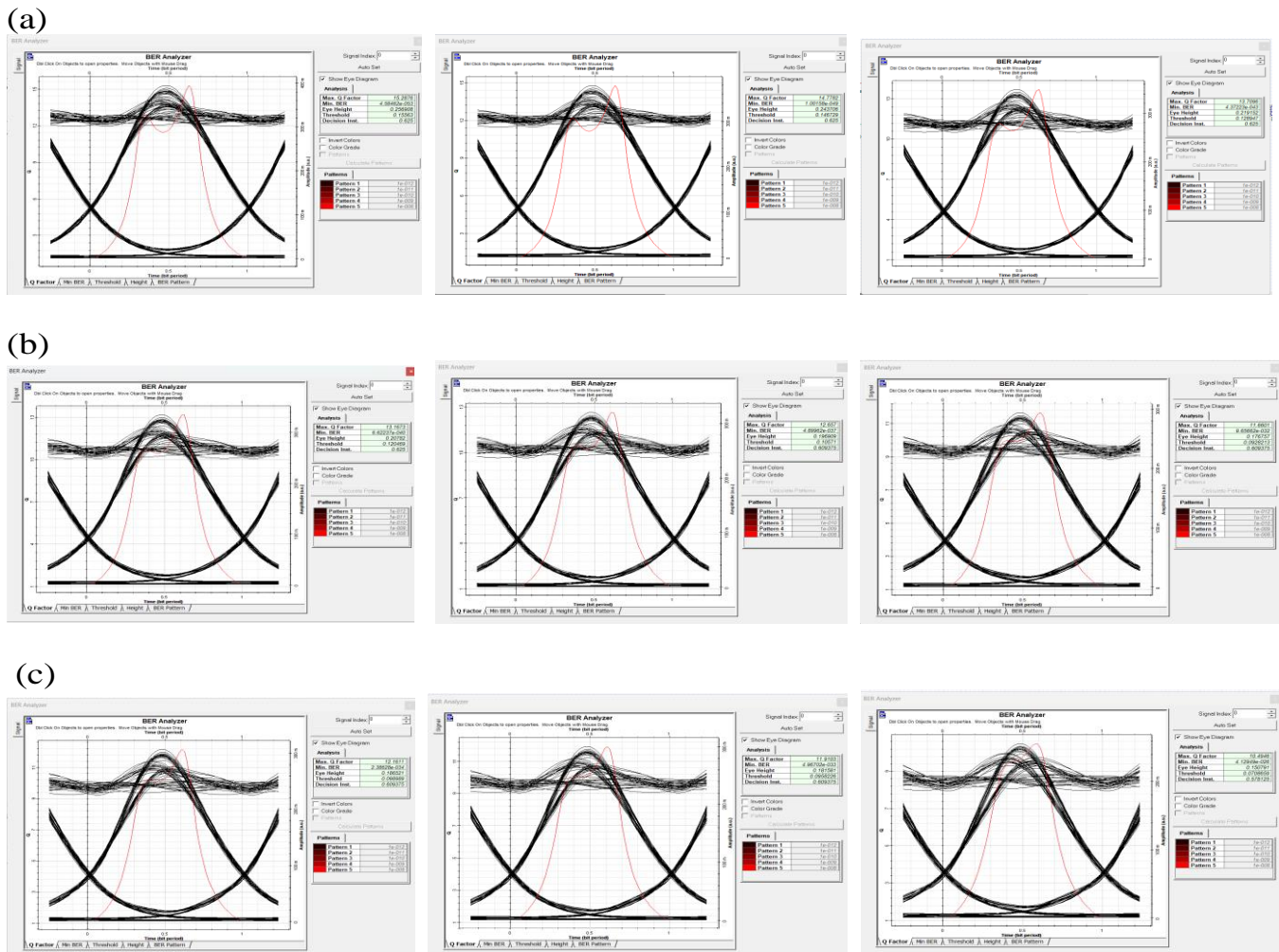

Figure (7): Eye diagram of the 320 Gbps DWDM system without the EDFA presentation at 60 km, 120 km, and 180 km, respectively for (a) channel 1, (b) channel 4, and (c) channel 8.

3.3. Q-Factor Parameter

The most crucial indicator of the reliability of our suggested system was the quality factor (Q-factor) parameter. It has therefore been investigated by elucidating the relationship between the Q-factor and distance, as shown in Fig. 8. These findings revealed an inverse relationship between them because getting farther away would lower the signal quality received. Additionally, the Max Q-factor measurement for the channels 1, 4, and 8 as well as samples for the complete scheme were collected. Results from the Q-factor show that the 320 Gbps system performs better.

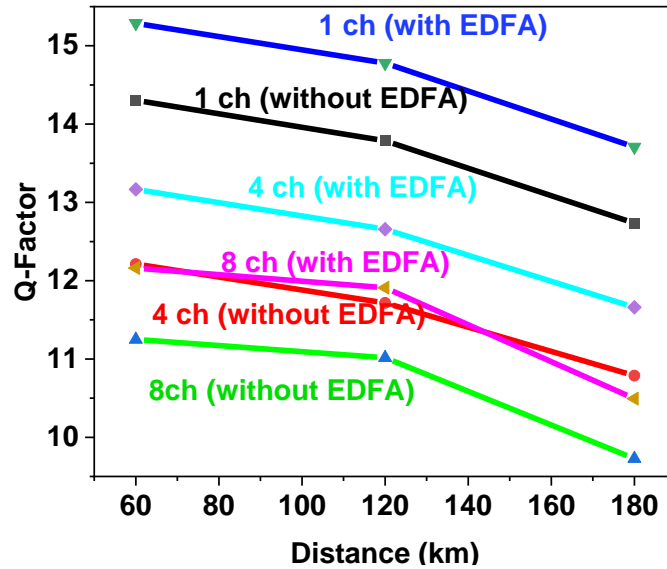

Figure (8): shows the maximum Q-factor value in relation to various channel distances.

3.4. Min BER Parameter

Fig. 9 show the link between the BER rates and the lengths of 60, 120, and 180 km, the advised system can be tested and evaluated over extended distances up to 180 km. It is acceptable to assume that there is a direct correlation between crosstalk and BER value given that the influence of distance increases the crosstalk and BER value.

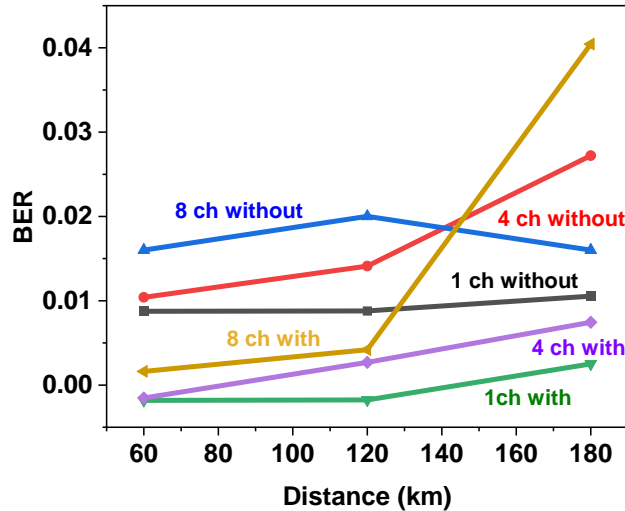

Figure (8): shows the minimum BER in relation to various channel distances.

4. Conclusion

In this work, the performance of the simulative comparisons and investigation of an 8-channel communication system for different distances of 80, 120, and 180 km is enhanced and maximized by applying EDFA to overcome

the effect of attenuation in the propagating channel. The proposed system achieved good results in enhancing signals due to EDFA. The performance of the system is evaluated in terms of BER, Q factor, and eye diagrams. The results would improve communication performance in the meantime to achieve better communication quality, enhanced network utilization, long-distance uninterrupted communication, faster data transfer speeds, support for real-time communication, and, of course, a reduction in the cost of communication.

References

- [1] Yusuf, M. (2019). Gain Enhancement Of Erbium Doped Fiber Amplifier Using Ase Reinjection (Doctoral Dissertation, Uttarakhand Technical University).
- [2] Mahmood, A. I., Naser, H. A., & Lateef, A. T. (2023, September). Impact of fiber Bragg grating as dispersion compensator on optical communication systems. In AIP Conference Proceedings (Vol. 2804, No. 1). AIP Publishing.
- [3] Sivarajan, K. N. (2010). The optical transport network revolution. In Networking Workshop (Vol. 2).
- [4] Mukherjee, B. (2006). Optical WDM networks. Springer Science & Business Media.
- [5] Lateef, A. T., Naser, H. A., & Kadhim, A. K. (2023, March). Comparing of the effect of changing weather factors on FSO communication system performance using iterative improvement technique. In AIP Conference Proceedings (Vol. 2591, No. 1). AIP Publishing.
- [6] Naser, H. A., Ali, H. H., & Ali, H. R. (2023, February). Utilizing a High-Sensitive and Secure Communication System for Data Transmission. In 2023 Second International Conference on Advanced Computer Applications (ACA) (pp. 1-5). IEEE.
- [7] Akage, Y., Kawano, K., Oku, S., Iga, R., Okamoto, H., Miyamoto, Y., ... & Penniman, S. K. Agrawal, G. P.(2001). Nonlinear Fiber Optics. Academic Press, San Diego, Agrawal, G. P.(2002). Fiber-optic Communication Systems. Wiley-Interscience, New York, Agrawal, GP and Dutta, NK (1986). Long-Wavelength Semiconductor Lasers. Van Norstrand-Reinhold, Princeton, NJ. J. Solid-state Circuits, 30(12), 1399-1410.
- [8] Dutta, A. K., Dutta, N. K., & Fujiwara, M. (Eds.). (2004). WDM technologies: optical networks. Elsevier.
- [9] Cranch, G. A., & Nash, P. J. (2001). Large-scale multiplexing of interferometric fiber-optic sensors using TDM and DWDM. Journal of lightwave technology, 19(5), 687.
- [10] Masuda, H., & Kawai, S. (1999). Wide-band and gain-flattened hybrid fiber amplifier consisting of an EDFA and a multiwavelength pumped Raman amplifier. IEEE Photonics Technology Letters, 11(6), 647-649. 47-52). SPIE.
- [11] Borraccini, G., D'Amico, A., Straullu, S., Usmani, F., Ahmad, A., & Curri, V. (2023). Iterative supervised learning approach using transceiver bit-error-rate measurements for optical line system optimization. Journal of Optical Communications and Networking, 15, 111-118. <https://doi.org/10.1364/JOCN.475460>.
- [12] Pei, L., Chang, Y., Wang, J., Zheng, J., Ning, T., Li, J., Bai, B., Shen, L., & Zhong, L. (2023). Fiber Residual Stress Effects on Modal Gain Equalization of Few-Mode Fiber Amplifier.. Sensors, 23 5. <https://doi.org/10.3390/s23052574>.
- [13] Mishra, A., Kakade, R., & Kakade, P. (2022). Dual-Stage EDFA for Improving the Performance of Long-Haul Optical Systems. IEEE Access, 10, 13496-13514. <https://doi.org/10.1109/ACCESS.2022.3146978>.
- [14] Belmahdi, B., & Mazighi, K. (2022). Implementation Efficiency of a Two-Stage EDFA Amplifier with an Inverted Trapezoidal Filter on Gain Flattening. 2022 7th International Conference on Image and Signal Processing and their Applications (ISPA), 1-6. <https://doi.org/10.1109/ISPA54004.2022.9786288>.
- [15] Zhao, Z., Yang, A., & Peng, G. (2022). Optimization of EDFA position for high speed short reach PAM4 optical fiber communication systems. , 12278, 122780H - 122780H-7. <https://doi.org/10.1117/12.2616458>.
- [16] Mirza, J., Ghafoor, S., Salman, A., Habib, N., & Qureshi, K. (2022). Design of L + U-band Erbium-doped fiber amplifier based on a single S-band forward pump source. International Journal of Communication Systems, 35. <https://doi.org/10.1002/dac.5250>.
- [17] Takeshita, H., Nakamura, K., Matsuo, Y., Inoue, T., Masuda, D., Hiwatashi, T., Hosokawa, K., Inada, Y., & Gabory, E. (2023). Demonstration of Uncoupled 4-Core Multicore Fiber in Submarine Cable Prototype With Integrated Multicore EDFA. Journal of Lightwave Technology, 41, 980-988. <https://doi.org/10.1109/JLT.2022.3195190>.